

Features & Benefits

- Constant current design
- Patented “sandwich” design uses customer-supplied heatsink and integral mechanical and electrical interfaces to eliminate wiring harness
- Patented intelligent thermal design uses metal core board (MCPCB)
- Includes mounting holes for mechanical attachment
- Easily configured into existing and new luminaires
- Available in a variety of color temperatures
- Can be used to meet the requirements of CA Title 24, ENERGY STAR® and other green initiatives



Ratings and Performance Specifications

Nominal AC Power Consumption @ 120VAC	14.5W
Nominal Input Voltage	90-240VAC, 277VAC
Maximum Operating Range Ambient Temperature (Ta)	-20 to +50° C
Maximum Solder Pad Temperature (Ts)	+105° C
Maximum Screw Installation Torque.....	50 inch-ounces
Estimated Lumen Depreciation (LM80 standard)	70% of initial lumens (L70) at 40,000 hours
Maximum Weight	94 grams

Safety/Compliance:

LED module:

- UL Recognized Component E321468
- RoHs Compliant

BL25 Series Driver:

- UL Recognized Component E256806
- RoHs Compliant
- Output operating frequency ≥ 120Hz
- Meets FCC requirements for consumer use
- Class A sound rating
- Complies with IEEE C.62.41-1991, Class A operation

Application Notes

1. The use of any washer (lock, flat, etc.) with the specified truss head screw will void the warranty due to possible damage and/or shorting to the circuit board.
2. This “sandwich style” LED light engine makes electrical and mechanical connection with 4-40 x 3/8” truss head screws and isolation bushings. The screw heads must be a minimum diameter of 0.250” in order to seat properly on the module and not damage the contacts. Brillia recommends the use of an aluminum or equivalent heatsink “sandwiched” between the LED module and driver with a nominal thickness of 0.080”. For thicker heatsinks, longer screws can be used, however caution must be used not to bottom-out and damage the internal PC board of the driver. The isolation bushings must be McMaster Carr 91145A129 or Brillia PC61-0002 or equivalent dimensions and material.
3. The proper LED Solder Pad Temperature (Ts) is critical to ensure long life. Careful design consideration required for factors such as ambient conditions (for example weather and surrounding atmosphere inside exterior luminaires) and proximity to other heat sources such as other LED modules and heat generating LED drivers.
4. Abnormal operating conditions such as high humidity or elevated operating temperatures can be expected to negatively impact lumen output, product lifetime, or product performance.



Physical Dimensions

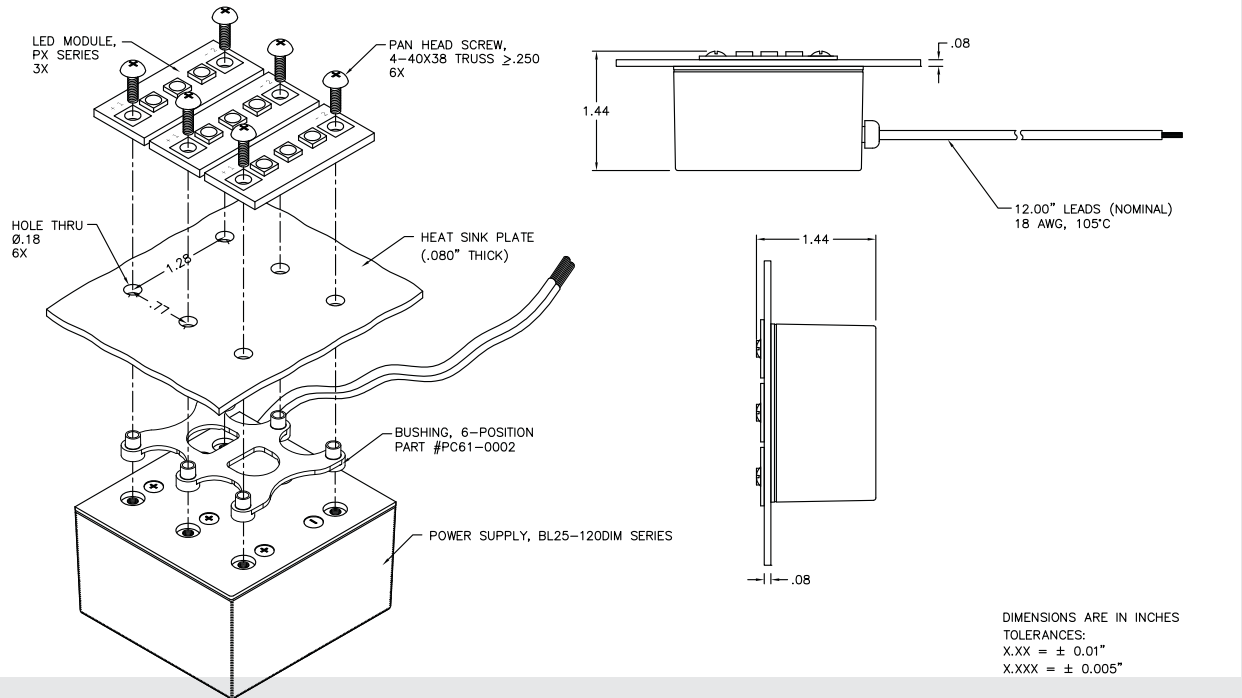

Part Number	Nominal Input Voltage	Nichia NS3x183 LED Package Bin	Nominal Values CCT Color Temp. (Kelvin)	Sample Values Light Output ^[2] (Lumens)	Sample Values Efficacy ^[2] (LPW)	Sample Values CRI ^[1]	Nominal Beam Angle (Degrees)	Nominal Input Voltage Dimmable (VAC)
BEP09BF240MNC27-001	90-240VAC	SW27	2700	570	45	80	120	No
BEP09BF240MNC35-001	90-240VAC	SW35	3500	675	54	80	120	No
BEP09BF240MNC51-001	90-240VAC	C1/C2	5100	750	60	70	120	No
BEP09BF277FNC27-001	277VAC	SW27	2700	570	44	80	120	No
BEP09BF277FNC35-001	277VAC	SW35	3500	675	52	80	120	No
BEP09BF277FNC51-001	277VAC	C1/C2	5100	750	58	70	120	No

¹Higher CRI available by special order

²Sample value when used with compatible Brillia LED driver and sample heatsink

Options

Other LED colors or LED manufacturersplease email sales@brillialed.com

Packaging

Brillia LED Light Engines are packed in individual containers with ESD bags as applicable and are marked with relevant SKU information and lot traceability.

Warranty

3-Year limited warranty in accordance with Brillia published warranty. Product must be used with compatible Brillia components (modules, drivers, engines and/or accessories) and no maximum ratings (such as Ts) shall be exceeded during any expected operating conditions of the system.

Permlight Products Inc. holds the following United States patents of which one or more may be applicable to the design and/or manufacture of this product. Additional granted patents, patents pending and other intellectual property protection rights may apply to this product.

United States Patents: 6712486, 6578986, 6846093, 7114831, 7306353, 7102172, 7108396, 7329024, 7387406, 7582911, 7582911, 7649327

www.brillialed.com